

JANUS CONTROL VALVE CHECK VALVE

The check valves are a unique range of valves which are supplied in 316 stainless steel and high grade engineering polymer as standard, for operation on tap water to EU directive 98/83/EC. Available in 3 sizes, the range offers consistent performance even after lengthy periods of inactivity.

SPECIFICATION				
	DN6	DN9	DN12	DN16
Pressure Range (bar)	0.1 - 200	0.1 - 200	0.1 - 200	0.1 - 200
Feed Gallery Diameter	6	9.5	12.7	16
Cv	0.65	0.65	1.92	4.5
Max Flow rate L/min	30	50	60	100
"A" Length	56.5	89	70	147.3
"B" A/F	25.6	22.2	29	42.4
"C" Thread	1/4" BSPP	3/8" BSPP	1/2" BSPP	3/4" BSPP

The sealing and control of flow occurs at 2 separate positions within the valve. This ensures the seals are not subjected to high fluid velocities minimising the potential of seal flow erosion.

Cracking Pressure

Cracking pressures from 0.1 bar to 3 bar are available. Standard valves are offered with 0.6 bar. If specific cracking pressures are required then please specify with order.

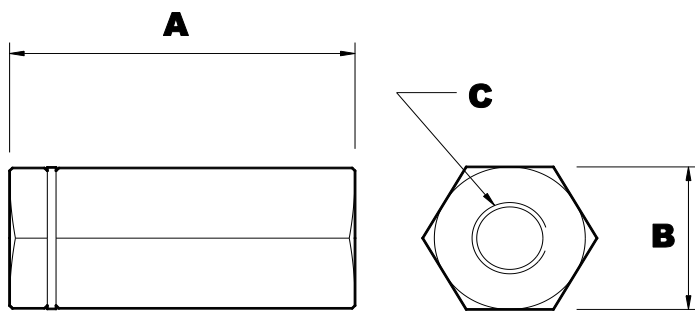

Dimensions



ORDERING CODES	DN6	DN9	DN12	DN16
 Check	210BXS	210CXS	210DXS	210EXS